

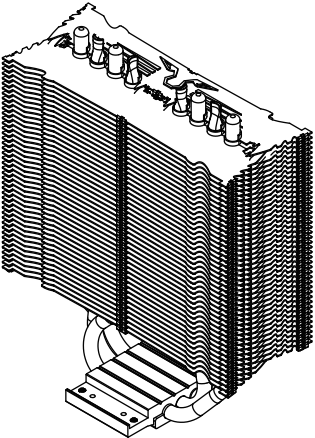
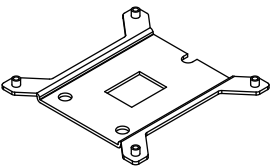
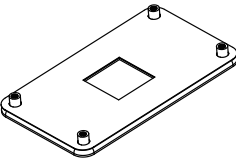
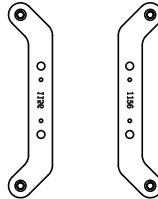
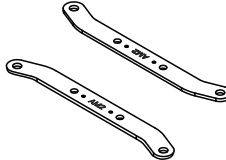

User Manual

Component						Russian																																																																								
										① Корпус радиатора	② Монтажная крестовина для обратной стороны платы Intel LGA1156	③ Монтажная крестовина для обратной стороны платы AM2/2+3	④ Опорный кронштейн 1156	⑤ Опорный кронштейн AM2/2+3	⑥ Винт M3 x 6	⑦ Подпружиненный винт	⑧ Зажимы для провода вентилятора 12025	⑨ Вентилятор 12025	⑩ Термокомпаунд																																																											
x 1	x 4	x 4	x 1	x 2	x 4	x 4	x 4	x 1	x 1																																																																					
English	Français	Deutsch	Italiano	日本語	한국어	繁體中文	Español																																																																							
① Heatsink Body	① Corps du dissipateur thermique	① Kühlkörper	① Corpo del dissipatore di calore	① ヒートシンク本体	① 히트싱크 바디	① 散熱器本體	① Cuerpo del disipador	② Intel LGA1156 Backplate	② Plaque arrière Intel LGA1156	② Intel LGA1156-Rückplatte	② Backplate Intel LGA1156	② Intel LGA1156 백플레이트	② Intel LGA1156 背板	② Placa de apoyo Intel LGA1156	③ AM2/2+3 Backplate	③ Plaque arrière AM2/2+3	③ AM2/2+3-Rückplatte	③ Backplate AM2/2+3	③ AM2/2+3 バックプレート	③ AM2/2+3 백플레이트	③ AM2/2+3 背板	③ Placa de apoyo AM2/2+3	④ Bracket Arm 1156	④ Bras de support 1156	④ Halterung für Socket 1156	④ Staffa 1156	④ ブラケットアーム 1156	④ 브래킷 암 1156	④ 1156 轉接板	④ Brazo de soporte 1156	⑤ Bracket Arm AM2/2+3	⑤ Bras de support AM2/2+3	⑤ AM2/2+3-Halterung	⑤ Staffa AM2/2+3	⑤ ブラケットアーム AM2/2+3	⑤ 브래킷 암 AM2/2+3	⑤ AM2/2+3 轉接板	⑤ Brazo de soporte AM2/2+3	⑥ M3 x 6 Screw	⑥ Vis M3 x 6	⑥ M3 x 6-Schraube	⑥ Vite M3 x 6	⑥ M3x 6ネジ	⑥ M3 x 6 나사	⑥ M3 x 6 螺絲	⑥ Tornillo M3 x 6	⑦ Spring-loaded Screw	⑦ Vis de pression	⑦ Federschraube	⑦ Vite a molla	⑦ バネネジ	⑦ 스프링 스크류	⑦ 彈簧螺絲	⑦ Tornillo de apriete por resorte	⑧ 12025 Fan Wire Clips	⑧ 12025 Clips métalliques de ventilateur	⑧ 12025 – Kühlerkabelclips	⑧ 12025 Fermagli cavo ventola	⑧ 12025 ファンケーブルクリップ	⑧ 12025 팬 클립	⑧ 12025 風扇線扣	⑧ 12025 Abrazaderas para cables del ventilador	⑨ 12025 Fan	⑨ 12025 Ventilateur	⑨ 12025 – Kühler	⑨ 12025 Ventola	⑨ 12025 ファンケーブルクリップ	⑨ 12025 팬	⑨ 12025 風扇	⑨ 12025 Ventilador	⑩ Thermal Compound	⑩ Composé thermique	⑩ Wärmeleitpaste	⑩ Composto termico	⑩ サーマルグリス	⑩ 썬열 컴파운드	⑩ 導熱膏	⑩ Compuesto térmico

Installation

* Refer to 1156 as reference.

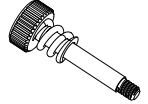
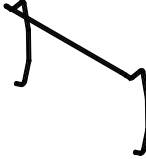
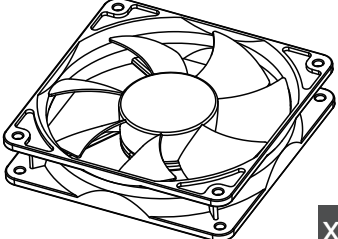
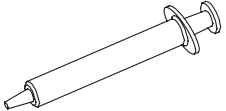
Step 1

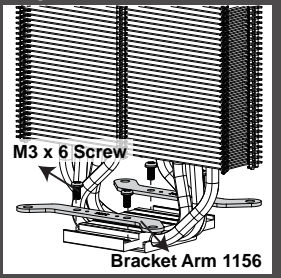

Step 2

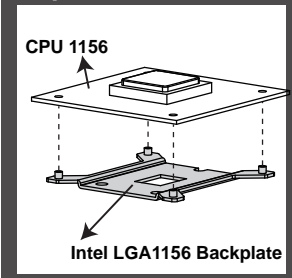

Step 4

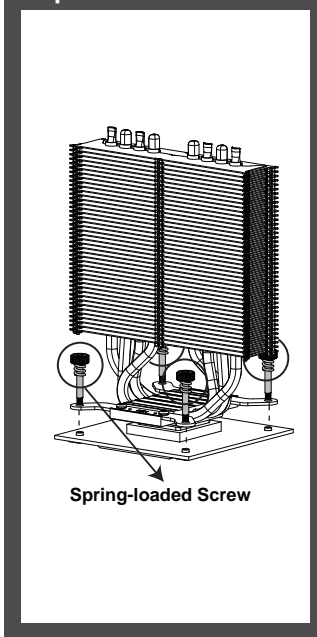

Step 5

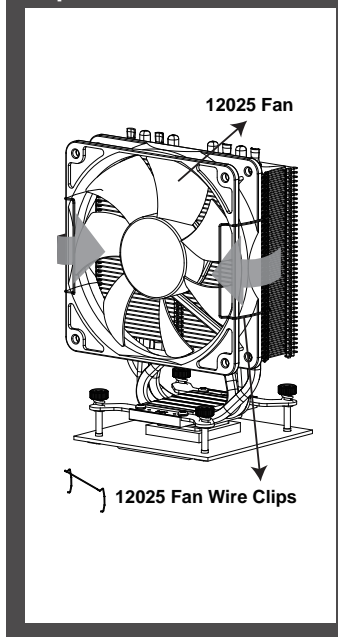

Step 3

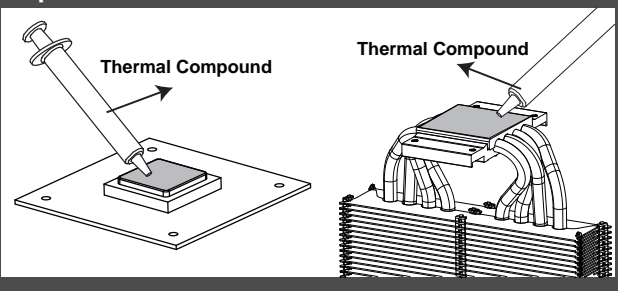

English	Russian
<p>Step 1 Use the M3 x 6 screws to secure the 1156/AMD bracket adapter to the heatsink.</p> <p>Step 2 Install the 1156/AMD backplate on the motherboard.</p> <p>Step 3 Spread out a thin layer onto the CPU and to the heatsink base bottom.</p> <p>Step 4 Use the spring-loaded screws to secure the heatsink on the motherboard.</p> <p>Step 5 Attach the fan mounting clips to the heatsink. Secure the fan with fan mounting clips.</p>	<p>Шаг 1 Винтами М3 х 6 закрепите кронштейн крепления 1156/AMD на радиаторе.</p> <p>Шаг 2 Установите монтажную крестовину для обратной стороны платы 1156/AMD на материнской плате.</p> <p>Шаг 3 Нанесите тонкий слой термокомпаунда на процессор и нижнюю часть радиатора.</p> <p>Шаг 4 С помощью подпружиненных винтов закрепите радиатор на материнской плате.</p> <p>Шаг 5 Прикрепите монтажные зажимы вентилятора к радиатору. Закрепите радиатор с помощью зажимов.</p>

Français	Deutsch	Italiano	Español	繁體中文	日本語	한국어
<p>Etape 1 Utilisez les vis M3 x 6 pour fixer l'adaptateur du support 1156/AMD au radiateur.</p> <p>Etape 2 Installez la plaque arrière 1156/AMD sur la carte mère.</p> <p>Etape 3 Étalez une petite couche sur l'adaptateur central et sur le dessous de la base du dissipateur thermique.</p> <p>Etape 4 Utilisez les vis à ressort pour fixer le radiateur à la carte mère.</p> <p>Etape 5 Attachez les clips de montage du ventilateur sur le dissipateur thermique. Attachez le ventilateur avec les clips de montage du ventilateur.</p>	<p>Schritt 1 Befestigen Sie den 1156/AMD-Halterungsadapter mit sechs M3-Schrauben am Kühlkörper.</p> <p>Schritt 2 Installieren Sie die 1156/AMD-Rückplatte am Motherboard.</p> <p>Schritt 3 Verteilen Sie eine dünne Schicht Wärmeleitpaste gleichmäßig auf der Oberseite der CPU und auf der Unterseite des Kühlkörpers.</p> <p>Schritt 4 Befestigen Sie den Kühlkörper mit den Federschrauben am Motherboard.</p> <p>Schritt 5 Befestigen Sie die Lüftermontageklammen am Kühlkörper. Sichern Sie den Lüfter mit den Lüftermontageklammen.</p>	<p>Fase 1 Usare le 6 viti M3 per fissare il supporto adattatore 1156/AMD al dissipatore di calore.</p> <p>Fase 2 Installa sulla scheda madre la piastra 1156/AMD.</p> <p>Fase 3 Stendere uno strato sottile sulla CPU e sulla base del dissipatore di calore.</p> <p>Fase 4 Usare le viti a molla per fissare il dissipatore di calore alla scheda madre.</p> <p>Fase 5 Attaccare i fermagli di montaggio ventola al dissipatore di calore. Fissare la ventola con i fermagli di montaggio ventola.</p>	<p>Paso 1 Utilice los 6 tornillos M3 para asegurar el adaptador del soporte 1156/AMD al disipador.</p> <p>Paso 2 Instale la placa posterior 1156/AMD en la placa base.</p> <p>Paso 3 Extienda una capa fina en la CPU y en la parte inferior de la base del disipador.</p> <p>Paso 4 Utilice los tornillos de apriete por resorte para fijar el disipador en la placa base.</p> <p>Paso 5 Acople las abrazaderas de montaje del ventilador en el disipador. Fije el ventilador con las abrazaderas de montaje.</p>	<p>步驟一 將1156 or AMD轉接板用 M3 x 6螺絲鎖到散熱器上。</p> <p>步驟二 將1156 or AMD背板裝到主機板上。</p> <p>步驟三 分別將CPU及散熱器銅底均勻塗上導熱膏。</p> <p>步驟四 依序用四支彈簧螺絲 將散熱器鎖至主機板上。</p> <p>步驟五 將風扇線扣扣住風扇，即完成。</p>	<p>手順1 1156 or AMDアダプタをM3 x 6のネジでクーラーに取り付けます。</p> <p>手順2 1156 or AMDのバックプレートをマザーボードに取り付けます。</p> <p>手順3 CPUの上とヒートシンクベースの底部まで薄層を広げます。</p> <p>手順4 順序の通りに4本のスプリングボルトで、クーラーをマザーボードにしっかりと止めます。</p> <p>手順5 ファン固定クリップでファンを固定して取り付け完了です。</p>	<p>1 단계 1156 or AMD도터 보드용 M3 x 6 나사를 라디에이터에 고정한다.</p> <p>2 단계 1156 or AMD 백플레이트를 마더 보드에 장착한다.</p> <p>3 단계 CPU 와 히트싱크 베이스 바닥에 고르게 얇게 바릅니다.</p> <p>4 단계 스프링 나사 4개를 순서대로 사용해, 라디에이터를 마더 보드에 고정한다.</p> <p>5 단계 팬 지지 클립으로 팬을 고정시키면 설치가.</p>